

EMC TEST REPORT

For

Shen Zhen Linsn Technology Development Co., Ltd

Optical Fiber Converter Single-mode/Multi-mode

Model No. : **SC701(Single-mode)** , MC701(Multi-mode)

Prepared for : Shen Zhen Linsn Technology Development Co., Ltd
5/F, Xinhaofang Bldg, NO. 188 Shennan Rd, Nanshan District,
Shenzhen City, Guangdong province, P.R. china.

Prepared By : Shenzhen AOV Testing Technology Co., Ltd.
2-6/F, No.5, Yuantou Lane, Tanglang, Taoyuan Street,
Nanshan District, Shenzhen, Guangdong, China

Tel : (86) 755-86008000
Fax : (86) 755-86008282

Report No. : ASZ090716090E

Date of Test : July 16-20, 2009

Date of Rep. : July 21, 2009

TABLE OF CONTENT

Description	Page
Test Report Declaration	
1. GENERAL INFORMATION.....	5
1.1. Description of Device (EUT)	5
1.2. Test Facility	6
1.3. Uncertainty	6
2. TEST INSTRUMENT USED	7
3. POWER LINE CONDUCTED EMISSION TEST	8
3.1. Block Diagram of Test Setup	8
3.2. Test Standard	8
3.3. Power Line Conducted Emission Limit	8
3.4. EUT Configuration on Test	8
3.5. Operating Condition of EUT	9
3.6. Test Procedure	9
3.7. Power Line Conducted Emission Test Results.....	9
4. RADIATED EMISSION TEST.....	10
4.1. Block Diagram of Test Setup	10
4.2. Test Standard	10
4.3. EUT Configuration on Test	11
4.4. Operating Condition of EUT	11
4.5. Test Procedure	11
4.6. Radiated Emission Test Result	12
5. HARMONIC CURRENT EMISSION TEST.....	13
5.1. Block Diagram of Test Setup	13
5.2. Test Standard	13
5.3. Operating Condition of EUT	13
5.4. Test Results	13
6. VOLTAGE FLUCTUATIONS & FLICKER TEST	14
6.1. Block Diagram of Test Setup	14
6.2. Test Standard	14
6.3. Operating Condition of EUT	14
6.4. Test Results	14
7. ELECTROSTATIC DISCHARGE TEST	15
7.1. Block Diagram of Test Setup	15
7.2. Test Standard	15
7.3. Severity Levels and Performance Criterion.....	15
7.4. EUT Configuration on Test	16
7.5. Operating Condition of EUT	16
7.6. Test Procedure	16
7.7. Test Results	16
8. RF FIELD STRENGTH SUSCEPTIBILITY TEST	18
8.1. Block Diagram of Test Setup	18
8.2. Test Standard	18
8.3. Severity Levels and Performance Criterion.....	19
8.4. EUT Configuration on Test	19
8.5. Operating Condition of EUT	19
8.6. Test Procedure	19

8.7. Test Results	19
9. ELECTRICAL FAST TRANSIENT/BURST TEST	21
9.1. Block Diagram of the EUT	21
9.2. Test Standard	21
9.3. Severity Levels and Performance Criterion.....	21
9.4. EUT Configuration on Test	22
9.5. Operating Condition of EUT	22
9.6. Test Procedure	22
9.7. Test Results	22
10. SURGE TEST	24
10.1. Block Diagram of Test Setup	24
10.2. Test Standard	24
10.3. Severity Levels and Performance Criterion.....	24
10.4. EUT Configuration on Test	25
10.5. Operating Condition of EUT	25
10.6. Test Procedure	25
10.7. Test Results	25
11. INJECTED CURRENTS SUSCEPTIBILITY TEST.....	27
11.1. Block Diagram of Test setup	27
11.2. Test Standard	27
11.3. Severity Levels and Performance Criterion.....	27
11.4. EUT Configuration on Test	27
11.5. Operating Condition of EUT	28
11.6. Test Procedure	28
11.7. Test Results	28
12. MAGNETIC FIELD IMMUNITY TEST.....	30
12.1. Block Diagram of Test Setup	30
12.2. Test Standard	30
12.3. Severity Levels and Performance Criterion.....	30
12.4. EUT Configuration on Test	31
12.5. Operating Condition of EUT	31
12.6. Test Procedure	31
12.7. Test Results	31
13. VOLTAGE DIPS AND INTERRUPTIONS TEST	33
13.1. Block Diagram of Test Setup	33
13.2. Test Standard	33
13.3. Severity Levels and Performance Criterion.....	33
13.4. EUT Configuration on Test	34
13.5. Operating Condition of EUT	34
13.6. Test Procedure	34
13.7. Test Result	34
14. TEST SETUP PHOTOGRAPH	36
14.1. Photo of Radiated Emission Test	36
APPENDIX I ----- Power Line Conducted Emission Test Data	
APPENDIX II----- Radiated Emission Test Data	
APPENDIX III----- Photographs of the EUT	

TEST REPORT DECLARATION

Applicant : Shen Zhen Linsn Technology Development Co., Ltd
 Manufacturer : Hui Dong Country Zhida Electronics Limited
 EUT Description : Optical Fiber Converter Single-mode/Multi-mode

(A) Model No. : **SC701(Single-mode)**, MC701(Multi-mode)
 (B) Serial No. : E2009072102W
 (C) Power Supply : Input AC230V/50Hz

Test Procedure Used:

EMI: EN55022: 2006+A1: 2007
 EN61000-3-2: 2006, EN61000-3-3: 1995+A1: 2001+A2: 2005

EMS: EN55024: 1998+A1: 2001+A2: 2003 (EN61000-4-2: 1995+A1: 1998+A2: 2001,
 EN61000-4-3: 2006, EN61000-4-4: 2004,
 EN61000-4-5: 2006, EN61000-4-6: 1996+ A1: 2001,
 EN61000-4-8: 1993+A1: 2001, EN61000-4-11: 2004)

The device described above has been tested by **Shenzhen AOV Testing Technology Co., Ltd.** to determine the maximum emission levels emanating from the device, the severe levels that the device can endure and EUT'S performance criterion. The test results are contained in this test report. **Shenzhen AOV Testing Technology Co., Ltd.** is assumed of full responsibility for the accuracy and completeness of these tests. Also, this report shows that the EUT is technically compliant with the EN55022, EN61000-3-2, EN61000-3-3 and EN55024 requirements.

This report applies to above tested sample only and shall not be reproduced in part without written approval of **Shenzhen AOV Testing Technology Co., Ltd.**

Date of Test: July 16-20, 2009

Prepared by: Project Engineer

Approved & Authorized Signer: Project Manager

1. GENERAL INFORMATION

1.1. Description of Device (EUT)

Description : Optical Fiber Converter Single-mode/Multi-mode

Model Number : **SC701(Single-mode)** , MC701(Multi-mode)
They are quite same in circuit design and PCB layout, so all Tests of this report are perform model SC701(Single-mode).

Applicant : Shen Zhen Linsn Technology Development Co., Ltd
Address : 5/F, Xinhaofang Bldg, NO. 188 Shennan Rd, Nanshan District, Shenzhen City, Guangdong province, P.R. china.

Manufacturer : Shen Zhen Linsn Technology Development Co., Ltd
Address : 5/F, Xinhaofang Bldg, NO. 188 Shennan Rd, Nanshan District, Shenzhen City, Guangdong province, P.R. china.

Date of Test : July 16-20, 2009

1.2. Test Facility

Test Firm : Bontek Compliance Testing Laboratory Ltd.
Certificated by FCC, Registration No.: 338263
Address : FL.1, Building H-3, Hua Qiao Cheng East Industrial Area
Qiaocheng East Road, Nanshan, Shenzhen, P.R.China
Tel : 86-755-86337020
Fax : 86-755-86337028

1.3. Uncertainty

Conducted Emission Uncertainty = $\pm 2.23\text{dB}$

Radiated Emission Uncertainty = $\pm 4.26\text{dB}$

2. TEST INSTRUMENT USED

No.	Equipment	Manufacturer	Model No.	S/N	Cal date
1	EMI Test Receiver	R&S	ESPI	100687	2009-2-22
2	EMI Test Receiver	R&S	ESPI7	100097	2009-2-22
3	Amplifier	HP	8447D	1937A02492	2009-2-22
4	Single Power Conductor Module	FCC	FCC-LISN-5-50-1-01-CISPR25	07101	2009-2-22
5	TRILOG Broadband Test-Antenna	SCHWARZBECK	VULB9163	9163-324	2009-2-22
6	Horn Antenna	SCHWARZBECK	BBHA9120A	B08000991-0001	2009-2-22
7	High Field Biconical Antenna	ELECTRO-METRICS	EM-6913	166	2009-2-22
8	Log Periodic Antenna	ELECTRO-METRICS	EM-6950	811	2009-2-22
9	Remote Active Vertical Antenna	ELECTRO-METRICS	EM-6892	304	2009-2-22
10	Power Clamp	SCHWARZBECK	MDS-21	3812	2009-2-22
11	Single Power Conductor Module	FCC	FCC-LISN-5-50-1-01-CISPR25	07102	2009-2-22
12	Teo Line Single Phase Module	SCHWARZBECK	NSLK8128	D-69250	2009-2-22
13	Positioning Controller	C&C	CC-C-1F	MF7802113	2009-2-22
14	Electrostatic Discharge Simulator	TESEQ	NSG437	125	2009-2-22
15	Fast Transient Burst Generator	SCHAFFNER	MODULA6150	34572	2009-2-22
16	Fast Transient Noise Simulator	Noiseken	FNS-105AX	31485	2009-2-22
17	Capacitive Coupling Clamp	TESEQ	CDN8014	25096	2009-2-22
18	Color TV Pattern Generator	PHILIPS	PM5418	TM209947	N/A
19	Power Frequency Magnetic Field Gene	EVERFINE	EMS61000-8K	608002	2009-2-22
20	Triple-Loop Antenna	EVERFINE	LLA-2	607004	2009-2-22
21	10dB attenuator	SCHWARZBECK	MTAIMP-136	R65.90.0001#06	2009-2-22

3. POWER LINE CONDUCTED EMISSION TEST

3.1. Block Diagram of Test Setup

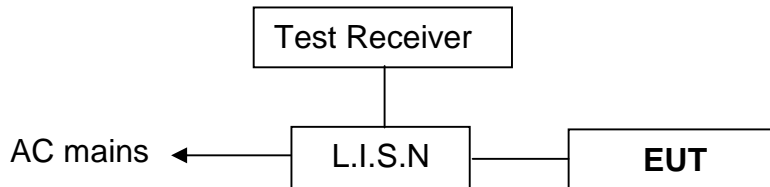

(EUT: Optical Fiber Converter Single-mode/Multi-mode)

3.2. Test Standard

EN55022: 2006+A1:2007

3.3. Power Line Conducted Emission Limit

Frequency MHz	Limits (dB μ V)	
	Quasi-peak Level	Average Level
0.15 ~ 0.50	66 ~ 56*	56 ~ 46*
0.50 ~ 5.00	56	46
5.00 ~ 30.00	60	50

- Notes:
1. *Decreasing linearly with logarithm of frequency.
 2. The lower limit shall apply at the transition frequencies.

3.4. EUT Configuration on Test

The following equipments are installed on conducted emission test to meet EN55022 requirement and operating in a manner that tends to maximize its emission characteristics in a normal application.

3.4.1 Optical Fiber Converter Single-mode/Multi-mode (EUT)

Model Number : SC701(Single-mode)
 Serial Number : E2009072101W
 Manufacturer : Shen Zhen Linsn Technology Development Co., Ltd

3.5. Operating Condition of EUT

3.5.1 Setup the EUT and simulators as shown in Section 3.1.

3.5.2 Turn on the power of all equipments.

3.5.3 Let the EUT work in test mode and test it.

3.6. Test Procedure

The EUT is put on the table that is 0.8m high above the ground and connected to the AC mains through Artificial Mains Network (AMN). This provided a 50 ohms coupling impedance for the tested equipments. Both sides of AC line are checked to find out the maximum conducted emission levels according to EN55022 class B regulations during conducted emission test.

The bandwidth of the test receiver (R&S Test Receiver ESP17) is set at 120 KHz.

The frequency range from 150 KHz to 30 MHz is investigated. The test data are listed in the Section 3.7, and the test data has been listed in APPENDIX I.

3.7. Power Line Conducted Emission Test Results

PASS.

The frequency range 150 KHz to 30MHz is investigated.

4. RADIATED EMISSION TEST

4.1. Block Diagram of Test Setup

4.1.1. Block Diagram of EUT Test Setup



(EUT: Optical Fiber Converter Single-mode/Multi-mode)

4.1.2. Anechoic Chamber Setup Diagram

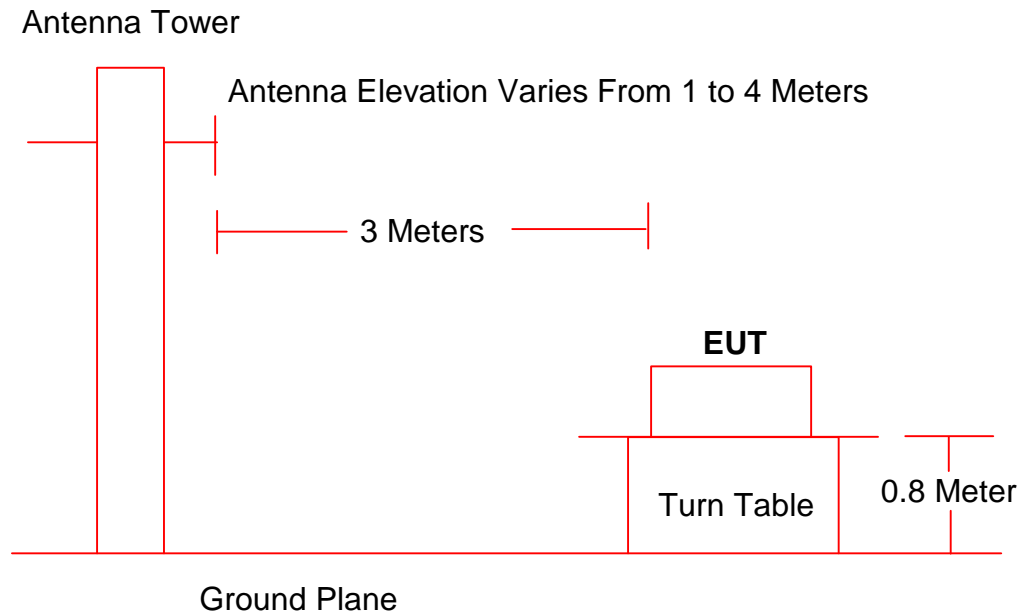

(EUT: Optical Fiber Converter Single-mode/Multi-mode)

4.2. Test Standard

EN55022: 2006+A1:2007

4.2.1. Radiated Emission Limit

Frequency MHz	Distance (Meter/s)	Field Strengths Limits dB(μV)/m
30 ~ 230	3	40.0
230 ~ 1000	3	47.0

- Remark:
- (1) Emission level (dB(μV)/m) = 20 log Emission level (μV/m)
 - (2) The smaller limit shall apply at the cross point between two frequency bands.
 - (3) Distance refers to the distance in meters between the measuring instrument, antenna and the closed point of any part of the device or system.

4.3.EUT Configuration on Test

The EN55022 regulations test method must be used to find the maximum emission during radiated emission test.

4.4.Operating Condition of EUT

- 4.4.1. Setup the EUT and simulators as shown in Section 4.1.
- 4.4.2. Turn on the power of all equipments.
- 4.4.3. Let the EUT work in test mode and test it.

4.5. Test Procedure

The EUT and its simulators are placed on a turned table that is 0.8 meter above the ground. The turned table can rotate 360 degrees to determine the position of the maximum emission level. The EUT is set 3 meters away from the receiving antenna that is mounted on the antenna tower. The antenna can move up and down between 1 meter and 4 meters to find out the maximum emission level. Broadband antenna (calibrated biconical and log periodical antenna) is used as receiving antenna. Both horizontal and vertical polarization of the antenna is set on test. In order to find the maximum emission levels, the interface cable must be manipulated according to EN55022 on radiated emission test.

The bandwidth setting on the field strength meter (R & S Test Receiver ESPI) is set at 120 KHz.

The frequency range from 30 MHz to 1000 MHz is investigated. The test data are listed in the Section 4.7, and the test data has been listed in APPENDIX II.

4.6. Radiated Emission Test Result

PASS.

The frequency spectrum from 30 MHz to 1000 MHz is investigated.

Detailed information, please see the appendix (II) file.

5. HARMONIC CURRENT EMISSION TEST

5.1. Block Diagram of Test Setup

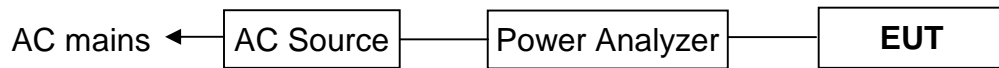

(EUT: Optical Fiber Converter Single-mode/Multi-mode)

5.2. Test Standard

EN61000-3-2: 2006

5.3. Operating Condition of EUT

Same as Section 3.5 except the test set up replaced by Section 5.1.

5.4. Test Results

PASS.

6. VOLTAGE FLUCTUATIONS & FLICKER TEST

6.1. Block Diagram of Test Setup

Same as Section 5.1

6.2. Test Standard

EN61000-3-3: 1995+A1: 2001+A2: 2005

6.3. Operating Condition of EUT

Same as Section 3.5

6.4. Test Results

PASS.

7. ELECTROSTATIC DISCHARGE TEST

7.1. Block Diagram of Test Setup

7.1.1. Block Diagram of EUT Test Setup

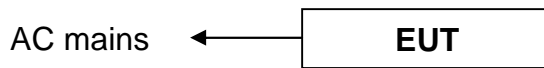

(EUT: Optical Fiber Converter Single-mode/Multi-mode)

7.1.2. ESD Test Setup

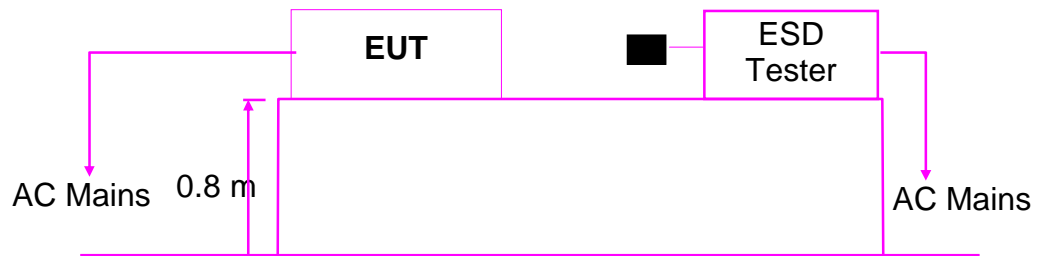

Remark: ■ is Discharge Electrode

(EUT: Optical Fiber Converter Single-mode/Multi-mode)

7.2. Test Standard

EN 55024: 1998 + A1: 2001 + A2: 2003
(EN 61000-4-2: 1995 + A1: 1998 + A2: 2001)

7.3. Severity Levels and Performance Criterion

Severity Level 3 for Air Discharge at 8KV
Severity Level 2 for Contact Discharge at 4KV
Severity Level:

Level	Test Voltage Contact Discharge (KV)	Test Voltage Air Discharge (KV)
1.	2	2
2.	4	4
3.	6	8
4.	8	15
X.	Special	Special

Performance criterion: **B**

7.4. EUT Configuration on Test

The configuration of EUT is listed in Section 3.4.

7.5. Operating Condition of EUT

7.5.1. Setup the EUT as shown in Section 7.1.

7.5.2. Turning on the power of all equipments.

7.5.3. Let the EUT work in test mode and test it.

7.6. Test Procedure

7.6.1. Air Discharge:

This test is done on a non-conductive surface. The round discharge tip of the discharge electrode shall be approached as fast as possible to touch the EUT. After each discharge, the discharge electrode shall be removed from the EUT. The generator is then re-triggered for a new single discharge and repeated 10 times for each pre-selected test point. This procedure shall be repeated until all the air discharge completed.

7.6.2. Contact Discharge:

All the procedure shall be same as Section 7.6.1 except that the tip of the discharge electrode shall touch the EUT before the discharge switch is operated.

Indirect discharge for horizontal coupling plane

At least 20 single discharges shall be applied to the horizontal coupling plane, at points on each side of the EUT. The discharge electrode position is vertically at a distance of 0.1m from the EUT and with the discharge electrode touching the coupling plane.

Indirect discharge for vertical coupling plane

At least 20 single discharges shall be applied to the center of one vertical edge of the coupling plane. The coupling plane, of dimensions 0.5m X 0.5m, is placed parallel to, and positioned at a distance of 0.1m from the EUT. Discharges shall be applied to the coupling plane, with this plane in sufficient different positions that the four faces of the EUT are completely illuminated.

7.7. Test Results

PASS.

Detailed information, Please refer to the following page.

Electrostatic Discharge Test Results

EUT	: Optical Fiber Converter Single-mode/Multi-mode	Temperature	: 25°C
M/N	: SC701(Single-mode)	Humidity	: 55%
Power Supply	: AC 230V/50Hz	Test Mode	: Full Load
<p>Air Discharge: $\pm 8KV$ For each point positive 10 times and negative 10 times discharge.</p> <p>Contact Discharge: $\pm 4KV$ For Contact Discharge each point positive 50 times and negative 50 times discharge</p>			
Location	Kind A-Air Discharge C-Contact Discharge	Result	
Slot	A	PASS	
HCP	C	PASS	
VCP of Front	C	PASS	
VCP of Rear	C	PASS	
VCP of Left	C	PASS	
VCP of Right	C	PASS	
<p>Remark: Discharge should be considered on Contact and Air and Horizontal Coupling Plane (HCP) and Vertical Coupling Plane (VCP).</p>		<p>Test Equipment: See Clause 2.</p>	

8. RF FIELD STRENGTH SUSCEPTIBILITY TEST

8.1. Block Diagram of Test Setup

8.1.1. Block Diagram of EUT Test Setup

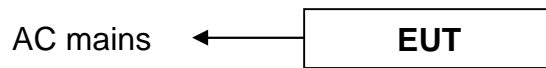

(EUT: Optical Fiber Converter Single-mode/Multi-mode)

8.1.2. R/S Test Setup

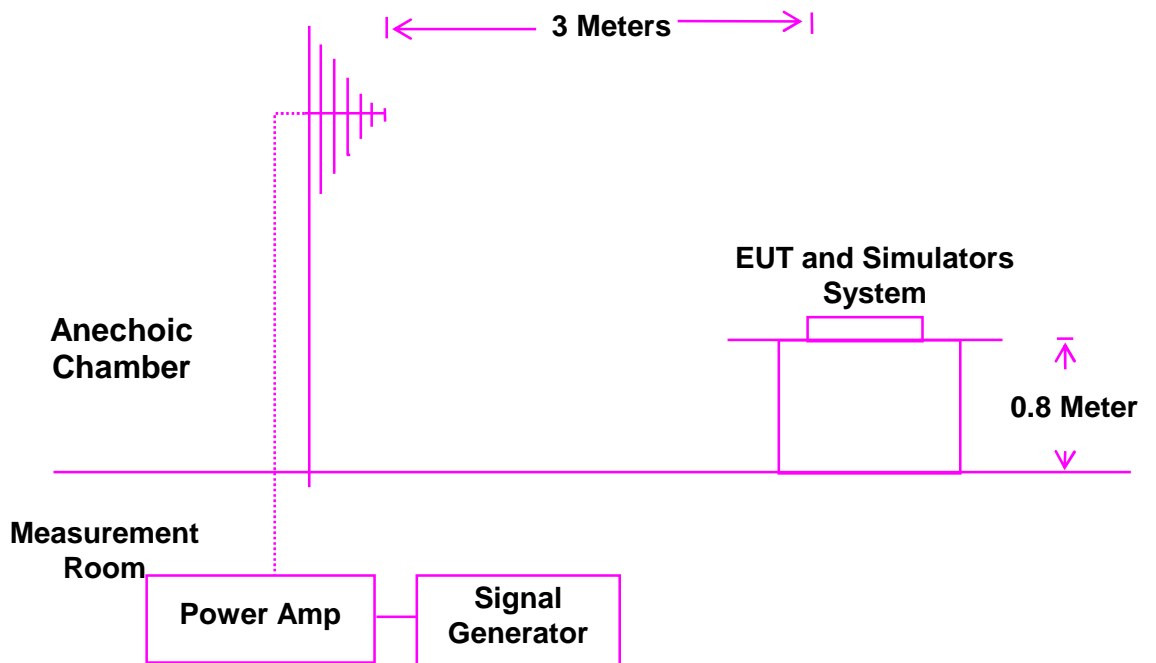

(EUT: Optical Fiber Converter Single-mode/Multi-mode)

8.2. Test Standard

EN 55024: 1998 + A1: 2001 + A2: 2003 (EN 61000-4-3: 2006)

8.3. Severity Levels and Performance Criterion

Severity Level 2 at 3V / m, Severity Level:

Level	Field Strength V/m
1.	1
2.	3
3.	10
X.	Special

Performance criterion: **A**

8.4. EUT Configuration on Test

The configuration of EUT is listed in Section 3.4.

8.5. Operating Condition of EUT

- 8.5.1. Setup the EUT as shown in Section 8.1.
- 8.5.2. Turn on the power of all equipments.
- 8.5.3. Let the EUT work in test mode and test it.

8.6. Test Procedure

8.6.1. The EUT and its simulators are placed on a table that is 0.8 meter above the ground. The EUT is set 3 meters away from the transmitting antenna that is mounted on an antenna tower. Both horizontal and vertical polarizations of the antenna are set on test. Each of the four sides of EUT must be faced this transmitting antenna and measured individually. In order to judge the EUT performance, a CCD camera is used to monitor the EUT.

8.6.2. All the scanning conditions are as follows:

Condition of Test	Remarks
1. Fielded Strength	3 V/m (Severity Level 2)
2. Radiated Signal	Modulated
3. Scanning Frequency	80 - 1000 MHz
4. Sweeping time of radiated	0.0015 decade/s
5. Dwell Time	1 Sec.

8.7. Test Results

PASS.

Detailed information, Please refer to the following page.

RF Field Strength Susceptibility Test Results

EUT	: Optical Fiber Converter Single-mode/Multi-mode	Temperature	: 25°C
M/N	: SC701(Single-mode)	Humidity	: 55%
Power Supply	: AC 230V/50Hz	Test Mode	: Full Load
Modulation: <input checked="" type="checkbox"/> AM <input type="checkbox"/> Pulse <input type="checkbox"/> None 1 KHz 80%			
Frequency Range: 80MHz to 1000 MHz			
Steps	#	/	%
	Horizontal		Vertical
Front	Pass		Pass
Right	Pass		Pass
Rear	Pass		Pass
Left	Pass		Pass
<p>Test Equipment: See Clause 2.</p>			

9. ELECTRICAL FAST TRANSIENT/BURST TEST

9.1. Block Diagram of the EUT

9.1.1. Block Diagram of EUT Test Setup

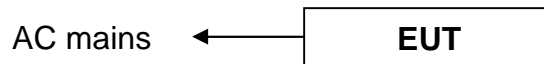

(EUT: Optical Fiber Converter Single-mode/Multi-mode)

9.1.2. Block Diagram of Test Setup

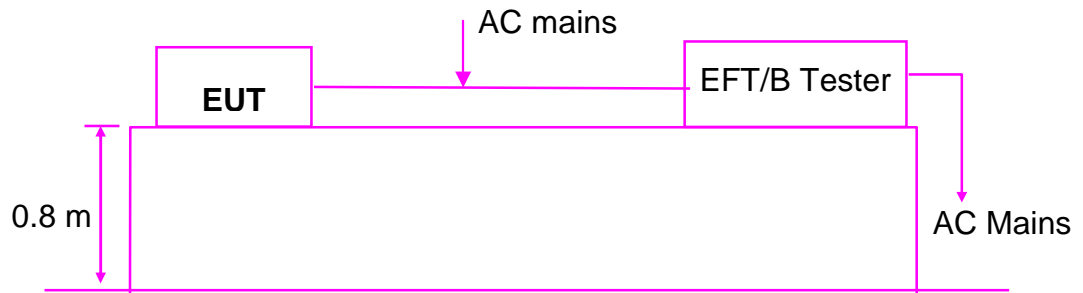

(EUT: Optical Fiber Converter Single-mode/Multi-mode)

9.2. Test Standard

EN 55024: 1998 + A1: 2001 + A2: 2003 (EN 61000-4-4: 2004)

9.3. Severity Levels and Performance Criterion

Severity Level 2 at 1KV

Severity Level:

Open Circuit Output Test Voltage $\pm 10\%$		
Level	On Optical Fiber Converter Single-mode/Multi-mode Lines	On I/O (Input/Output) Signal data and control lines
1.	0.5 KV	0.25 KV
2.	1 KV	0.5 KV
3.	2 KV	1 KV
4.	4 KV	2 KV
X	Special	Special

Performance criterion: **B**

9.4. EUT Configuration on Test

The configuration of EUT is listed in Section 3.4.

9.5. Operating Condition of EUT

- 9.5.1. Setup the EUT as shown in Section 9.1.
- 9.5.2. Turn on the power of all equipments.
- 9.5.3. Let the EUT work in test mode and test it.

9.6. Test Procedure

The EUT is put on the table that is 0.8 meter high above the ground. This reference ground plane shall project beyond the EUT by at least 0.1m on all sides and the minimum distance between the EUT and all other conductive structure, except the ground plane beneath the EUT, shall be more than 0.5m.

9.6.1. For input and output AC power ports:

The EUT is connected to the power mains by using a coupling device that couples the EFT interference signal to AC power lines. Both polarities of the test voltage should be applied during compliance test and the duration of the test is 2 minutes.

9.6.2. For signal lines and control lines ports:

No I/O ports.

9.6.3. For DC output line ports:

It's unnecessary to test.

9.7. Test Results

PASS.

Detailed information, Please refer to the following page.

Electrical Fast Transient/Burst Test Results

EUT	:	Optical Fiber Converter Single-mode/Multi-mode		Temperature	:	25°C			
M/N	:	SC701(Single-mode)		Humidity	:	55%			
Power Supply	:	AC 230V/50Hz		Test Mode	:	Full Load			
Inject Place: AC Mains									
Inject Line	Voltage KV	Inject Time(s)	Inject Method	Results	Inject Line	Voltage KV	Inject Time(s)	Inject Method	Results
L	±1	120	Direct	PASS					
N	±1	120	Direct	PASS					
L, N	±1	120	Direct	PASS					
Remark:					Test Equipment: See Clause 2.				

10. SURGE TEST

10.1. Block Diagram of Test Setup

10.1.1. Block Diagram of EUT Test Setup

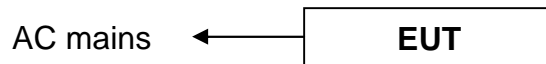

(EUT: Optical Fiber Converter Single-mode/Multi-mode)

10.1.2. Block Diagram of Test Setup

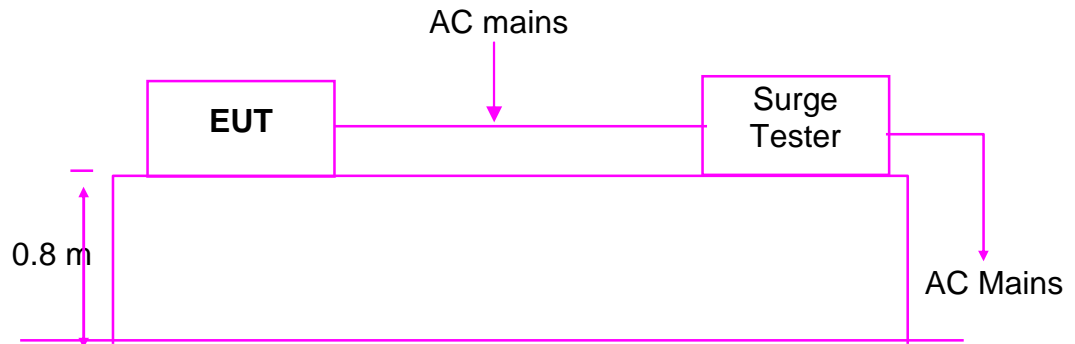

(EUT: Optical Fiber Converter Single-mode/Multi-mode)

10.2. Test Standard

EN 55024: 1998 + A1: 2001 + A2: 2003 (EN 61000-4-5: 2006)

10.3. Severity Levels and Performance Criterion

Severity Level 2 for Line to Neutral at 1.0KV

Severity Level:

Severity Level	Open-Circuit Test Voltage KV
1	0.5
2	1.0
3	2.0
4	4.0
*	Special

Performance criterion: **B**

10.4.EUT Configuration on Test

The configuration of EUT is listed in Section 3.4.

10.5.Operating Condition of EUT

10.5.1.Setup the EUT as shown in Section 10.1.

10.5.2.Turn on the power of all equipments.

10.5.3.Let the EUT work in test mode and test it.

10.6.Test Procedure

10.6.1.Set up the EUT and test generator as shown on Section 10.1.2.

10.6.2.For Line to Neutral coupling mode, provide a 0.5KV 1.2/50us voltage surge (at open-circuit condition) and 8/20us current surge to EUT selected points.

10.6.3.At least 5 positive and 5 negative (polarity) tests with a maximum 1/min repetition rate are conducted during test.

10.6.4.Different phase angles are done individually.

10.6.5.Record the EUT operating situation during compliance test and decide the EUT immunity criterion for above each test.

10.7.Test Results

PASS.

Detailed information, Please refer to the following page.

Surge Immunity Test Results

EUT	:	Optical Fiber Converter Single-mode/Multi-mode		Temperature	:	25°C
M/N	:	SC701(Single-mode)		Humidity	:	55%
Power Supply	:	AC 230V/50Hz		Test Mode	:	Full Load
Location	Polarity	Phase Angle	No of Pulse	Pulse Voltage (KV)	Result	
L-N	±1	0	5	1.0	PASS	
	±1	90	5	1.0	PASS	
	±1	180	5	1.0	PASS	
	±1	270	5	1.0	PASS	
Remark:			Test Equipment: See Clause 2.			

11. INJECTED CURRENTS SUSCEPTIBILITY TEST

11.1. Block Diagram of Test setup

11.1.1. Block Diagram of EUT Test Setup

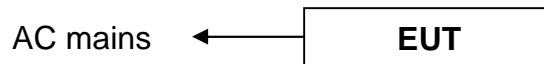

(EUT: Optical Fiber Converter Single-mode/Multi-mode)

11.1.2. Block Diagram of Test Setup

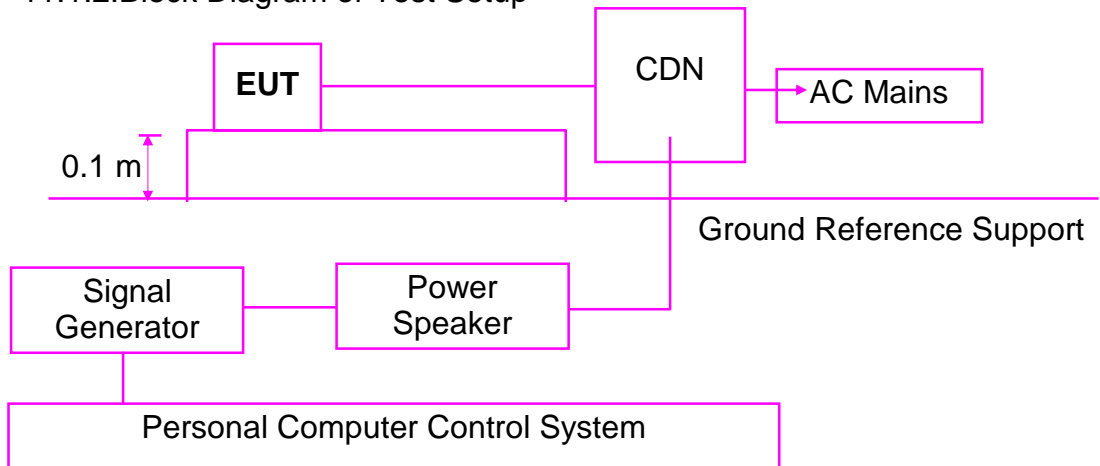

(EUT: Optical Fiber Converter Single-mode/Multi-mode)

11.2. Test Standard

EN 55024: 1998 + A1: 2001 + A2: 2003 (EN 61000-4-6: 1996 + A1: 2001)

11.3. Severity Levels and Performance Criterion

Severity Level 2 at 3V (rms), 0.15MHz ~ 80MHz

Severity Level:

Level	Field Strength V/m
1.	1
2.	3
3.	10
X.	Special

Performance criterion: **A**

11.4. EUT Configuration on Test

The configuration of EUT is listed in Section 3.4.

11.5. Operating Condition of EUT

- 11.5.1. Setup the EUT as shown in Section 11.1.
- 11.5.2. Turn on the power of all equipments.
- 11.5.3. Let the EUT work in test mode and test it.

11.6. Test Procedure

- 11.6.1. Set up the EUT, CDN and test generators as shown on Section
- 11.6.2. Let the EUT work in test mode and test it.
- 11.6.3. The EUT are placed on an insulating support 0.8m high above a ground reference plane. CDN (coupling and decoupling device) is placed on the ground plane about 0.3m from EUT. Cables between CDN and EUT are as short as possible, and their height above the ground reference plane shall be between 30 and 50 mm (where possible).
- 11.6.4. The disturbance signal described below is injected to EUT through CDN.
- 11.6.5. The EUT operates within its operational mode(s) under intended climatic conditions after power on.
- 11.6.6. The frequency range is swept from 150KHz to 80MHz using 3V signal level, and with the disturbance signal 80% amplitude modulated with a 1KHz sine wave.
- 11.6.7. The rate of sweep shall not exceed 1.5×10^{-3} decades/s. When the frequency is swept incrementally, the step size shall not exceed 1% of the start and thereafter 1% of the preceding frequency value.
- 11.6.8. Recording the EUT operating situation during compliance testing and decide the EUT immunity criterion.

11.7. Test Results

PASS.

Detailed information, Please refer to the following page.

Injected Currents Susceptibility Test Results

EUT	: Optical Fiber Converter Single-mode/Multi-mode	Temperature	: 25°C	
M/N	: SC701(Single-mode)	Humidity	: 55%	
Power Supply	: AC 230V/50Hz	Test Mode	: Full Load	
Frequency Range (MHz)	Injected Position	Strength	Criterion	Result
0.15 ~ 80	AC Line	3V(rms), Unmodulated	A	PASS
Remark: See Clause 2.		Note:		

12. MAGNETIC FIELD IMMUNITY TEST

12.1. Block Diagram of Test Setup

12.1.1. Block Diagram of EUT Test Setup

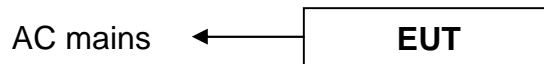

(EUT: Optical Fiber Converter Single-mode/Multi-mode)

12.1.2. Block Diagram of Test Setup

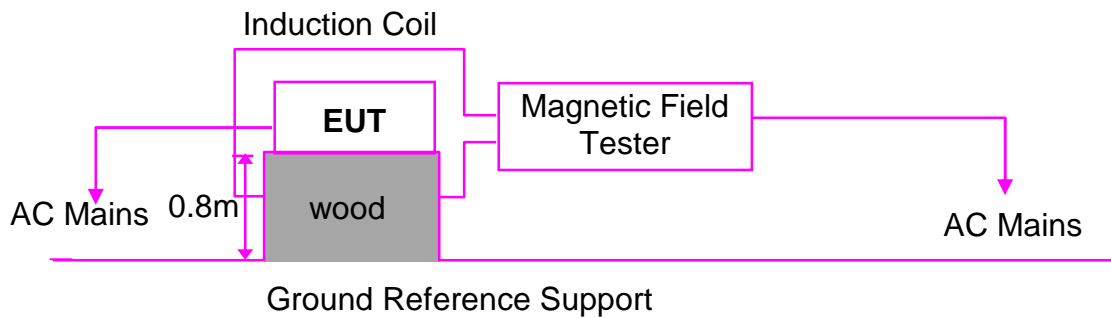

(EUT: Optical Fiber Converter Single-mode/Multi-mode)

12.2. Test Standard

EN 55024: 1998 + A1: 2001 + A2: 2003 (EN 61000-4-8: 1993 + A1: 2001)

12.3. Severity Levels and Performance Criterion

Severity Level 2 at 3A/m

Severity Level:

Level	Magnetic Field Strength A/m
1.	1
2.	3
3.	10
4.	30
5.	100
X.	Special

Performance criterion: **A**

12.4.EUT Configuration on Test

The configuration of EUT is listed in Section 3.4.

12.5.Operating Condition of EUT

12.5.1.Setup the EUT as shown in Section 12.1.

12.5.2.Turn on the power of all equipments.

12.5.3.Let the EUT work in test mode and test it.

12.6.Test Procedure

The EUT shall be subjected to the test magnetic field by using the induction coil of standard dimensions (1m*1m) and shown in Section 12.1.
2. The induction coil shall then be rotated by 90° in order to expose the EUT to the test field with different orientations.

12.7.Test Results

PASS.

Detailed information, Please refer to the following page.

Magnetic Field Immunity Test Results

EUT	:	Optical Fiber Converter Single-mode/Multi-mode	Temperature	:	25°C
M/N	:	SC701(Single-mode)	Humidity	:	55%
Power Supply	:	AC 230V/50Hz	Test Mode	:	Full Load
Test Level	Testing Duration	Coil Orientation	Criterion	Result	
3A/M	5 minutes	Horizontal	A	PASS	
3A/M	5 minutes	Vertical	A	PASS	
Remark:		Test Equipment: See Clause 2.			

13. VOLTAGE DIPS AND INTERRUPTIONS TEST

13.1. Block Diagram of Test Setup

13.1.1. Block Diagram of EUT Test Setup

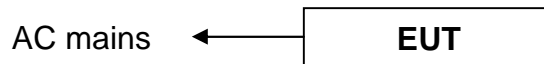

(EUT: Optical Fiber Converter Single-mode/Multi-mode)

13.1.2. Block Diagram of Test Setup

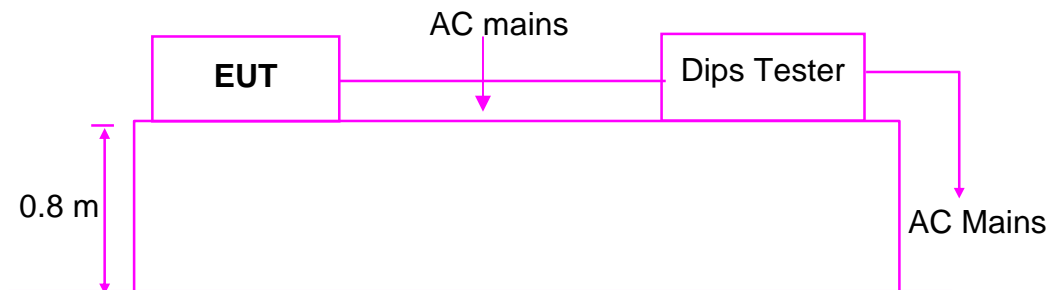

(EUT: Optical Fiber Converter Single-mode/Multi-mode)

13.2. Test Standard

EN 55024: 1998 + A1: 2001 + A2: 2003 (EN 61000-4-11: 2004)

13.3. Severity Levels and Performance Criterion

Severity Level:

Test Level $\%U_T$	Voltage dip and short interruptions $\%U_T$	Duration (in period)
0	100	0.5 1
40	60	5 10
70	30	25 50 *

Performance criterion: **B**

13.4.EUT Configuration on Test

The configuration of EUT is listed in Section 3.4.

13.5.Operating Condition of EUT

13.5.1.Setup the EUT as shown in Section 13.1.

13.5.2.Turn on the power of all equipments.

13.5.3.Let the EUT work in test mode and test it.

13.6.Test Procedure

13.6.1.Set up the EUT and test generator as shown on Section 13.1.2.

13.6.2.The interruption is introduced at selected phase angles with specified duration.

13.6.3.Record any degradation of performance.

13.7.Test Result

PASS.

Please refer to the following page.

Voltage Dips and Interruptions Test Results

EUT	: Optical Fiber Converter Single-mode/Multi-mode	Temperature	: 25°C
M/N	: SC701(Single-mode)	Humidity	: 55%
Power Supply	: AC 230V/50Hz	Test Mode	: Full Load

Test Level % U _T	Voltage Dips & Short Interruptions % U _T	Duration (in period)	Phase Angle	Criterion	Result
0	100	250P	90	B	PASS
40	60	5P	180	B	PASS
70	30	0.5P	270	B	PASS

Remark: U _T is the rated voltage for the equipment.	Test Equipment: See Clause 2.
---	----------------------------------

14. TEST SETUP PHOTOGRAPH

14.1. Photo of Power Line Conducted Emission Test



14.2. Photo of Radiated Emission Test

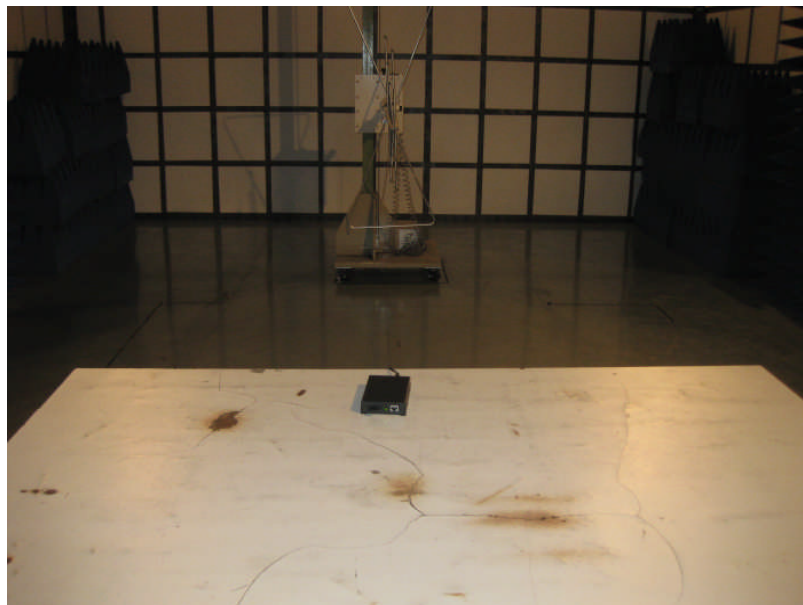

APPENDIX I

Power Line Conducted Emission Test Data

Power Line Conducted Emission

Engineer : William	
EUT : Optical Fiber Converter Single-mode/Multi-mode	Time : 2009/07/18
Limit : EN55022 Class B	Comment : 25°C/55%
MN: SC701(Single-mode)	Note : L
Power : AC 230V/50Hz	

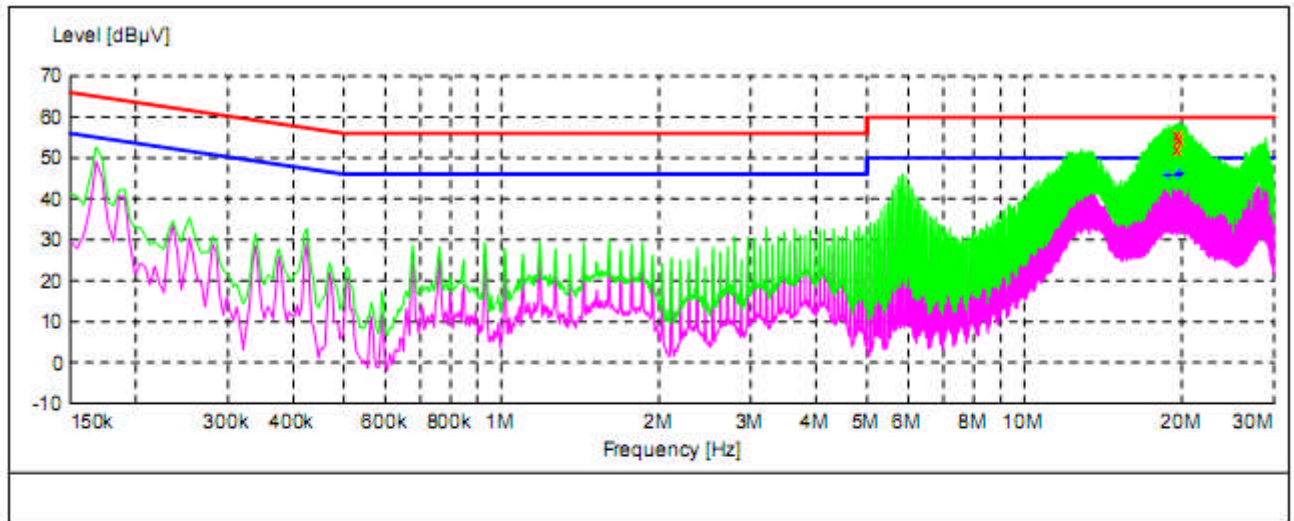

MEASUREMENT RESULT:

Frequency MHz	Level dBµV	Transd dB	Limit dBµV	Margin dB	Detector	Line	PE
19.504500	55.60	10.6	60	4.4	QP	L1	GND
19.576500	52.00	10.6	60	8.0	QP	L1	GND
19.752000	54.40	10.6	60	5.6	QP	L1	GND

MEASUREMENT RESULT:

Frequency MHz	Level dBµV	Transd dB	Limit dBµV	Margin dB	Detector	Line	PE
18.820500	45.90	10.6	50	4.1	AV	L1	GND
19.585500	45.80	10.6	50	4.2	AV	L1	GND
19.756500	46.40	10.6	50	3.6	AV	L1	GND

Power Line Conducted Emission

Engineer : William	
EUT : Optical Fiber Converter Single-mode/Multi-mode	Time : 2009/07/18
Limit : EN55022 Class B	Comment : 25°C/55%
MN: SC701(Single-mode)	Note : N
Power : AC 230V/50Hz	

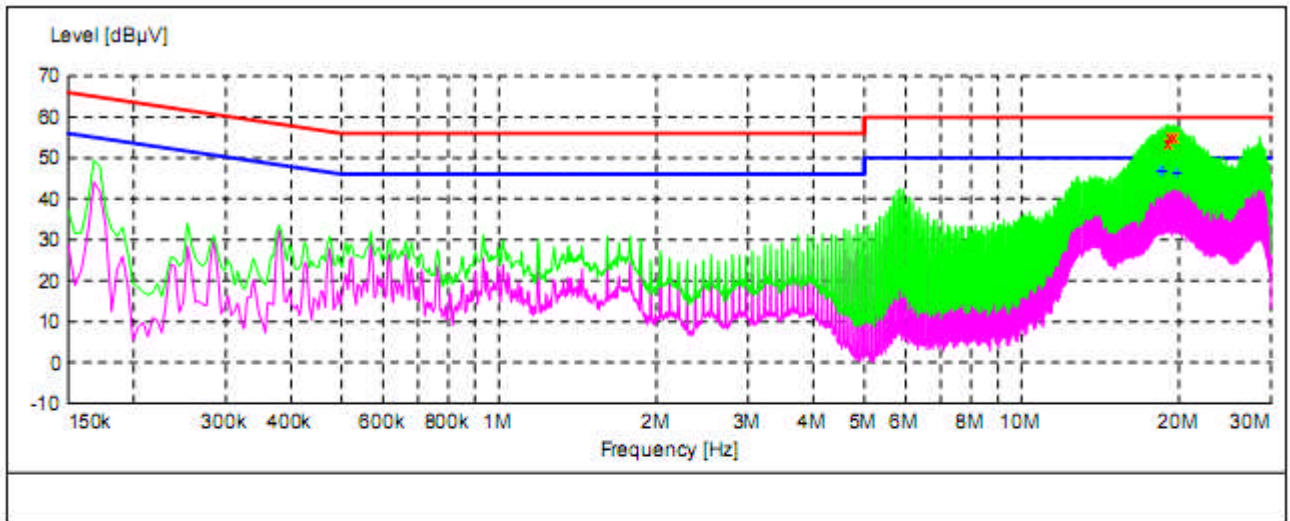

MEASUREMENT RESULT:

Frequency MHz	Level dBµV	Transd dB	Limit dBµV	Margin dB	Detector	Line	PE
19.018500	53.50	10.6	60	6.5	QP	N	GND
19.275000	55.00	10.6	60	5.0	QP	N	GND
19.621500	55.20	10.6	60	4.8	QP	N	GND

MEASUREMENT RESULT:

Frequency MHz	Level dBµV	Transd dB	Limit dBµV	Margin dB	Detector	Line	PE
18.424500	46.60	10.6	50	3.4	AV	N	GND
18.595500	46.70	10.6	50	3.3	AV	N	GND
19.783500	46.10	10.6	50	3.9	AV	N	GND

APPENDIX II

Radiated Emission Test Data

Radiated Emission

Engineer : William	
EUT : Optical Fiber Converter Single-mode/Multi-mode	Time : 2009/07/18
Limit : EN55022 CLASS B	Comment : 25°C/55%
MN: SC701(Single-mode)	Note : Hor
Power : AC 230V/50Hz	

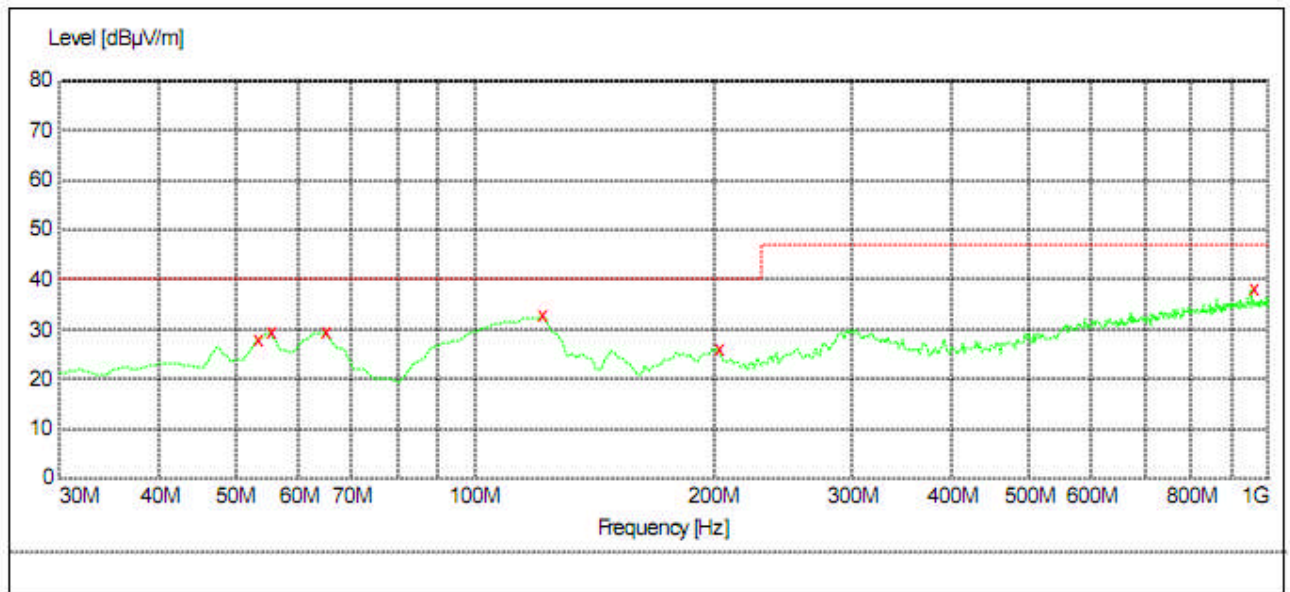
MEASUREMENT RESULT:

Frequency MHz	Level dBµV/m	Transd dB	Limit dBµV/m	Margin dB	Det.	Height cm	Azimuth deg	Polarization
53.280000	27.70	16.6	40.0	12.3	---	100.0	0.00	HORIZONTAL
55.220000	29.40	16.5	40.0	10.6	---	100.0	0.00	HORIZONTAL
64.920000	29.40	14.4	40.0	10.6	---	100.0	0.00	HORIZONTAL
121.180000	32.60	15.8	40.0	7.4	---	100.0	0.00	HORIZONTAL
202.660000	25.90	16.9	40.0	14.1	---	100.0	0.00	HORIZONTAL
935.380000	38.00	29.7	47.0	9.0	---	100.0	0.00	HORIZONTAL

Radiated Emission

Engineer : William	
EUT : Optical Fiber Converter Single-mode/Multi-mode	Time : 2009/07/18
Limit : EN55022 CLASS B	Comment : 25°C/55%
MN: SC701(Single-mode)	Note : Ver
Power : AC 230V/50Hz	

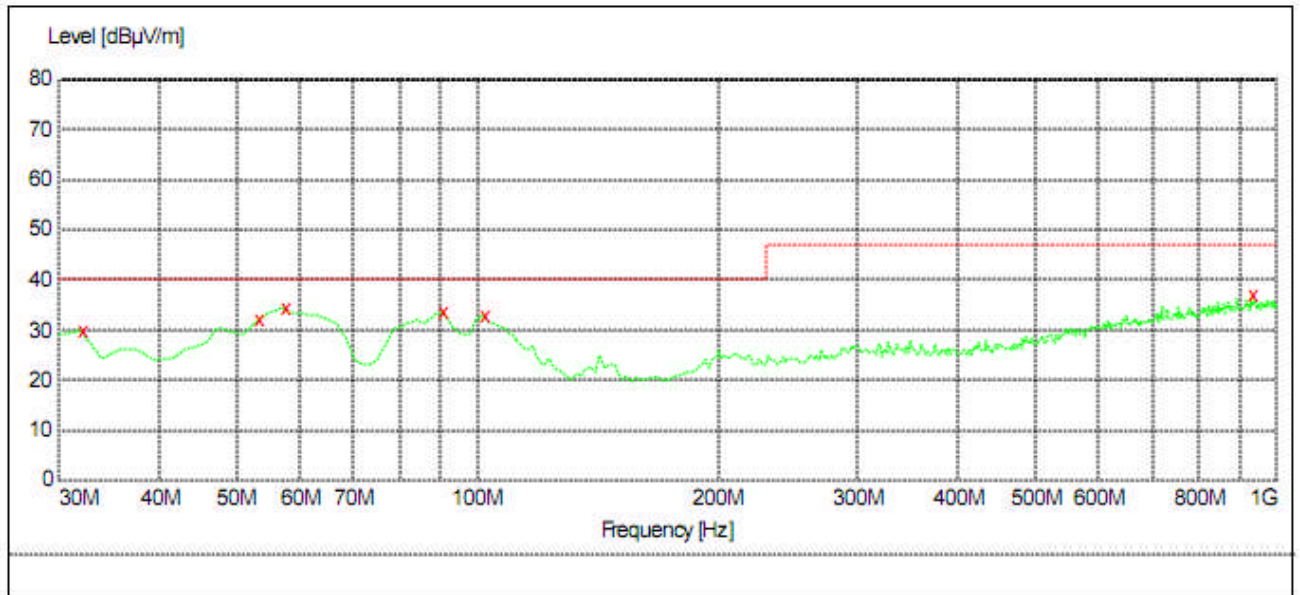
MEASUREMENT RESULT:

Frequency MHz	Level dBµV/m	Transd dB	Limit dBµV/m	Margin dB	Det.	Height cm	Azimuth deg	Polarization
31.940000	29.90	15.4	40.0	10.1	---	100.0	0.00	VERTICAL
53.280000	32.00	16.6	40.0	8.0	---	100.0	0.00	VERTICAL
57.160000	34.30	16.0	40.0	5.7	---	100.0	0.00	VERTICAL
90.140000	33.60	17.0	40.0	6.4	---	100.0	0.00	VERTICAL
101.780000	32.90	18.2	40.0	7.1	---	100.0	0.00	VERTICAL
932.100000	36.70	29.5	47.0	10.3	---	100.0	0.00	VERTICAL

APPENDIX III

Photographs of the EUT

FIGURE 1
General Appearance of EUT (M/N: SC701(Single-mode), Front View)



FIGURE 2
General Appearance of EUT (M/N: SC701(Single-mode), Rear View)



FIGURE 3
Inside of EUT (M/N: SC701(Single-mode))

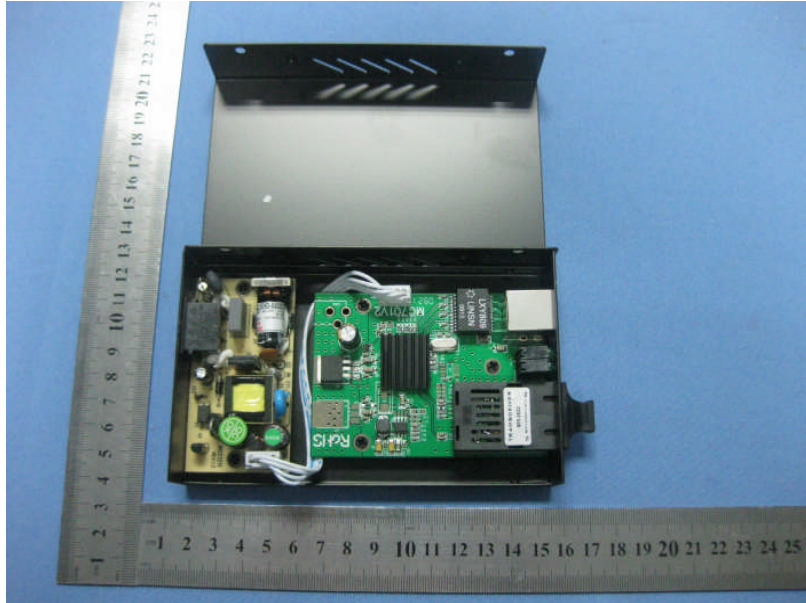

FIGURE 4
PCB of EUT (M/N: SC701(Single-mode), Front View)

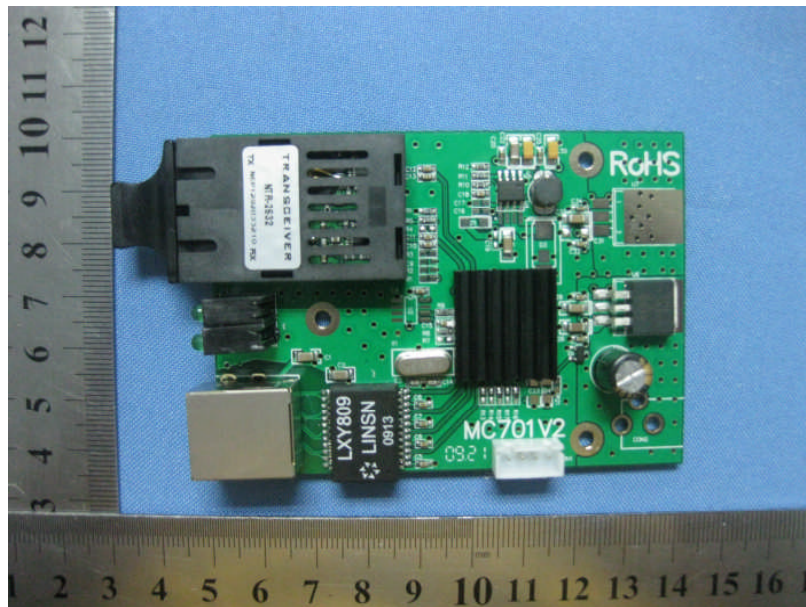

FIGURE 5
PCB of EUT (M/N: SC701(Single-mode), Rear View)

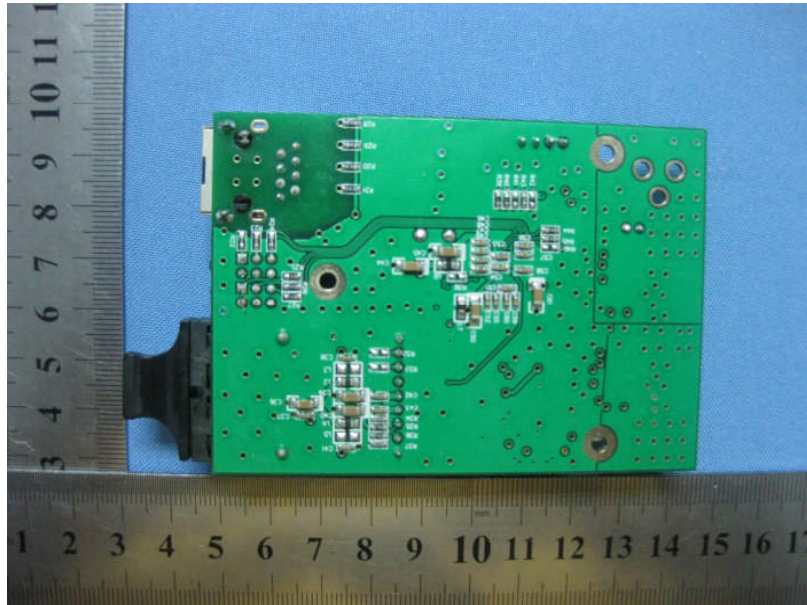

FIGURE 6
PCB of Power Source (M/N: SC701(Single-mode), Front View)

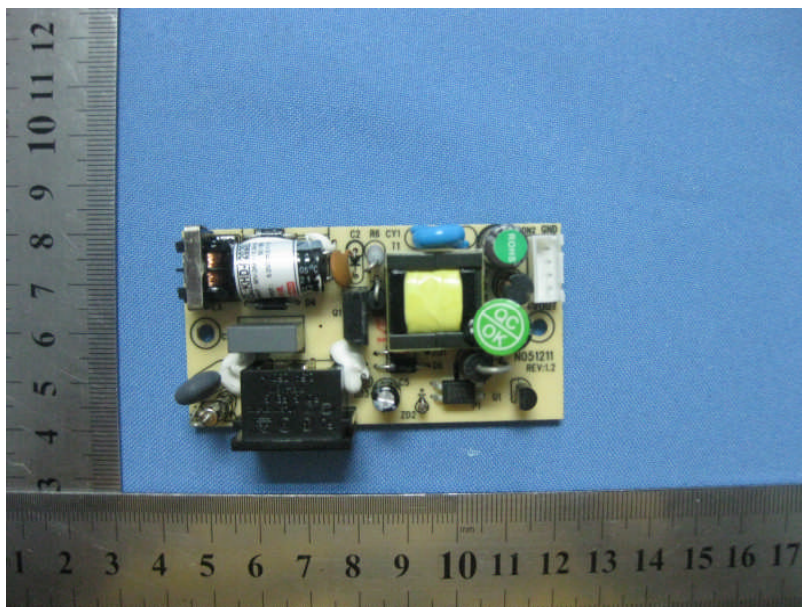

FIGURE 7
PCB of Power Source (M/N: SC701(Single-mode), Rear View)

